



**THE CORPORATION OF THE CITY OF NIAGARA FALLS
3200 STANLEY AVENUE, NIAGARA FALLS, ONTARIO, L2E 6S4
TELEPHONE 905-356-7521 FAX 905-356-1774
SUPPLY AND SERVICES**

REQUEST FOR QUOTATION - RFQ17-2012

MOBILE LIFTS - NIAGARA FALLS TRANSIT

CLOSING DATE: March 8, 2012 - 2:00 p.m.

Quotation submissions in response to this RFQ must be delivered **or faxed** (905-356-1774) to the Supply and Services Section, 3200 Stanley Avenue, Niagara Falls Ontario, L2E 6S4. Bidders who are delivering their Quotation submissions are to use the attached delivery label, which is the last page of this RFQ, using their own envelope.

Quotation submissions are invited for the supply and delivery of Mobile Lifts to be delivered F.O.B. Niagara Falls Transit, 4320 Bridge Street, Niagara Falls, Ontario L2E 2R7 all in accordance with this Request for Quotation. This Request for Quotation (RFQ) is also posted on the City of Niagara Falls web site at:

<http://www.niagarafalls.ca/bids>

QUESTIONS

Questions regarding this Request for Quotation are to be sent in writing only to Mr. Raymond Miller, Manager of Supply and Services, City of Niagara Falls, E-mail: rmiller@niagarafalls.ca no later than 1:00 p.m., February 29, 2012. Questions received later than this stated date and time may not be acknowledged nor answered.

SPECIFICATIONS

The Specifications are stated on the Specification Pages. The City may consider quotation submissions from Bidders that offer mobile lifts that are considered equal to or meet or exceed the specifications as stated in this RFQ. The City will not pre-determine alternatives. It is up to the Bidder to suggest alternatives (if any). The City will not engage in a process of pre-approving any suggested alternative mobile lifts that may be submitted to the City prior to the closing date of this Request for Quotation. The Bidder must consider the specifications and meet these specifications as appropriate.

MOBILE LIFTS - NIAGARA FALLS TRANSIT

RFQ17-2012

TABLE OF CONTENTS

Section	Description	Page
a)	RFQ Front Page.....	Page 1
b)	Table of Contents.....	Page 2
1	Instructions to Bidders.....	Pages IB 1 - IB 10
2	Price Schedule.....	Pages PS 1 -PS 2
3	Specifications Drawing: Mobile Lift Column... attached to Specifications	Pages SPC 1 - SPC 6
4	Delivery Label (if required).....	Last page of this RFQ

City of Niagara Falls
MOBILE LIFTS - NIAGARA FALLS TRANSIT
SECTION 1 - INSTRUCTIONS TO BIDDERS
RFQ17-2012

A. BIDDING PROCEDURE

1. Definitions:

“Bidder” means the company or person submitting a Quotation in response to this RFQ.

“City” shall be understood to mean The Corporation of The City of Niagara Falls.

“Contract” means City’s Purchase Order which shall include this RFQ and the Bidder’s Quotation submission.

“Purchase Order” means the official order as issued by the City to procure the goods as described in this RFQ.

“Quotation” means the Bidder’s Quotation submission

“RFQ” shall refer to this Request for Quotation

“Supplier” means the company to whom the City has issued a Purchase Order

2. RFQ Closing Time and Location

Quotations will be received in the Supply and Services Section 3200 Stanley Avenue, Niagara Falls, Ontario **no later than 2:00 p.m.** local time, **March 8, 2012**. Quotations received later than the time stated above may not be accepted. Bidders must instruct couriers and any who may be delivering your Quotation submission that the package or envelope **must be delivered only to the front reception area** at the Municipal Service Centre. Quotations delivered to any other facility or to any other area of the Municipal Service Centre may be rejected.

3. Bidding Procedure:

- a) Quotations must be submitted on the price schedule pages and any addenda to be either **faxed to 905-356-1774** or enclosed in the Bidders own envelope with the label (last page of this RFQ) affixed to the envelope. No bid deposit is required to be submitted with the Bidder’s Quotation submission.
- b) The Price Schedule page must be signed in the space provided on the form with the signature of the Bidder or responsible official of the firm submitting a Quotation.
- c) Bidder(s) will be permitted to withdraw their Quotation unopened after it has been deposited if such a request is received in writing to the City’s Manager of Supply & Services by the prior to the closing time specified herein.
- d) Collusion between Bidders will be sufficient cause for rejection of all Quotations so affected.
- e) The price(s) as submitted shall include the supply, delivery, warranty and service of all items described herein to complete this RFQ to the satisfaction of the City of Niagara Falls.
- f) The City of Niagara Falls will make all necessary corrections to any Quotation which is in error through addition or extensions with the corrected value prevailing.

4. Specifications

The Specifications are stated on the Specification Pages. The City may consider quotation submissions from Bidders that offer mobile lifts that are considered equal to or meet or exceed the specifications as stated in this RFQ. The City will not pre-determine alternatives. It is up to the Bidder to suggest alternatives (if any). The City will not engage in a process of pre-approving any suggested alternative mobile lifts that may be submitted to the City prior to the closing date of this Request for Quotation. The Bidder must consider the specifications and meet these specifications as appropriate.

5. Questions

Questions regarding this Request for Quotation are to be sent in writing only to Mr. Raymond Miller, Manager of Supply and Services, City of Niagara Falls, E-mail: rmiller@niagarafalls.ca no later than 1:00 p.m., February 29, 2012. Questions received later than this stated date and time may not be acknowledged nor answered.

RFQ17-2012
MOBILE LIFTS - NIAGARA FALLS TRANSIT
SECTION 1 - INSTRUCTIONS TO BIDDERS

6. Bidder's Submission

Bidders **must submit** the following documents with their Quotation Submission:

- Price Schedule Pages and including:

- All Price Schedule Pages
- Any Addenda posted on the City's Bid Opportunities Web Page
- Full warranty details on the Mobile Lifts offered
- Complete and Detailed Specifications for alternative mobile lifts offered (Per Price Schedule)

7. Addenda and Written Communications

The City will not be responsible for any verbal (spoken) information from any City staff or staff from any or consultant retained by the City or from any other person or persons who may have an interest in this RFQ. Adjustments or changes to this RFQ prior to the closing date and time stated herein will only be by written addenda only and said addenda will be posted electronically on the City's Bid Opportunity Website. It is the Bidder's sole responsibility to view this site often prior to the closing date and time stated herein to make themselves aware of any or all addenda which can be downloaded from this site. Any Quotation submitted to the City that does not include the first page (completed and signed) of all addenda issued may be rejected.

The City's Bid Opportunity Web Site is: <http://www.niagarafalls.ca/bids>

8. Evaluation

Quotation submissions may be evaluated on factors such as compliance with, or equal to the specifications and requirements of this RFQ, including delivery time, warranty, previous performance (sales, delivery and service) with the City or other customers if applicable, all requirements as stated in this RFQ and not necessarily price alone.

9. RFQ Requirements and the City's Rights

Notwithstanding any terms or conditions contained in this RFQ, the Corporation of the City of Niagara Falls reserves the right to add or delete requirements listed in this RFQ at any time. Also the City may issue a Purchase Order to one Supplier, or to two or more Suppliers or to cancel this RFQ for reasons that are in the best interest of and provide the best value for the City. The Bidder by submitting a Quotation in response to this RFQ thereby acknowledges that the City has these rights and the rights stated in the Instructions to Bidders Section.

10. Taxes

All Taxes to be **extra** to the unit prices stated on the Price Schedule.

**MOBILE LIFTS - NIAGARA FALLS TRANSIT
SECTION 1 - INSTRUCTIONS TO BIDDERS**

B. GENERAL REQUIREMENTS**1. Delivery of Quotation Submission**

For those Bidders who are delivering their Quotation submissions, the attached delivery label (last page) is to be affixed (glued) to an appropriate sized envelope, approximately 9" x 12" and submitted to the Corporation of the City of Niagara Falls prior to the closing date. **Quotations can also be faxed to 905-356-1774. Do not attach delivery label to faxed Quotations.** Delivered Quotations **must only** be to the **Front Reception**, Municipal Service Centre, 3200 Stanley Avenue, Niagara Falls, Ontario. Quotations delivered to any other section of the Municipal Service Centre, or any other location, or facility **will** result in the rejection of the Bidder's Quotation submission.

2. Clarification

It will be the Bidder's responsibility to clarify any details in question before submitting a Quotation. **Unless otherwise stated**, all official correspondence regarding this RFQ should be directed in writing to and will be issued by the Manager of Supply and Services or designate for The Corporation of the City of Niagara Falls. The City will assume no responsibility for oral instruction or suggestion.

3. Withdrawal of Quotations

Companies will be permitted to withdraw their Quotation submission, unopened after it has been deposited, if such a request is received by the Manager of Supply and Services or designate in writing, prior to the time specified for the closing of this RFQ.

4. Error & Correction

The City will make all necessary corrections to any Quotation submitted which is in error through addition or extension; the corrected value prevailing.

5. Rights of the City

- a) The City reserves the right, in its absolute discretion to accept a Quotation which it deems most advantageous to itself and the right to reject any or all Quotations, in each case without giving any notice. The lowest or any Quotation will not necessarily be accepted. In no event will the City be responsible for the costs of the preparation of the submission of a Quotation from any Bidder.
- b) Quotations which contain conditions or otherwise fail to conform to the Instructions to Bidders may be disqualified or rejected. The City may, however, in its sole discretion, reject or retain for its consideration Quotations, which are non-conforming because they do not contain the content or form required by the Instructions to Bidders or for failure to comply with the process for submission set out in the Instructions to Bidders.
- c) Except as expressly and specifically permitted in the Instructions to Bidders, no Bidder shall have any claim for any compensation of any kind whatsoever, as a result of participating in this Request for Quotation, and by submitting a Quotation each Bidder shall be deemed to have agreed that it has no claim.
- d) The City reserves the right to exercise complete and unfettered discretion in all aspects of the conduct of this RFQ and any subsequent procurement process, the assessment and evaluation of Quotation submissions, including the determination of criteria and choice of a Supplier, without incurring any liability whatsoever to any Bidder, including any liability for costs, expenses, losses or damages, and without giving any reason therefore.
- e) The City reserves the right to reject any Quotation submission which is restricted by any wording, sentences, clauses, copies or agreements or contract samples included by the Bidder in their Quotation submission. The City shall make the sole determination of which of the above constitutes a restriction. Also, Quotation submissions which are incomplete, conditional or obscure, or which contain additives not called for, erasures, alterations or irregularities of any kind, **will** be rejected

5. Rights of the City....continued

- f) The City in its sole and unfettered discretion, reserves the right to change the dates, schedules and deadlines set out in this RFQ or to change the scope of the project, or to cancel the RFQ or the project without stating any reasons therefor.
- g) The City reserves the right to accept or to reject any or all of the Quotation submissions and the City reserves the right to proceed, in its sole and unfettered discretion, following receipt of the Quotation submissions, to issue a modified Request for Quotation for the project or to cancel the RFQ process and any subsequent procurement process including the Purchase Order issued to a Supplier.
- h) The City reserves the right to negotiate any terms or conditions whatsoever with any Bidder following receipt of Quotation submissions in response to this RFQ.
- l) The Bidder agrees that by submitting a Quotation in response to this RFQ that the City has no obligation to reveal any information regarding any Quotation submitted to the City including the results of the RFQ process or any reasons for its decision in the choice of a Supplier or Suppliers.
- j) The City reserve the right to waive informalities at its sole discretion.

6. Notification to Bidders

Any notice that the City may be required or desired to give to the Bidder shall for all purposes be deemed to have been sufficiently and properly given if posted on the City's Bid Opportunities Web Page. It is the Bidder's sole responsibility to check the said Web Page to avail themselves of any posted RFQ or any addenda. The City's Bid Opportunities Web Page is: www.niagarafalls.ca/bids

7. Adherence to Requirements

The Bidder is requested to adhere strictly to all requirements and complete all sections of this RFQ including all appendices and addenda. Failure to do so may be sufficient cause for rejection of the Bidder's Quotation.

8. Taxes

Prices for Unit Prices to be exclusive of taxes.

9. Freedom of Information

Any information including the requirements as described in this RFQ, and including service or product details, prices, statements, and any other information provided by the Bidder shall be kept strictly confidential and release of same, except for any details regarding this RFQ stated in a report to the Council of the City, shall only be granted in accordance with the *Municipal Freedom of Information and Protection of Privacy Act* R.S.O. 1990, c. M.56 as amended.

10. Quotation Submissions Irrevocable

The Quotations received from Bidders are to be irrevocable and open for acceptance for a period of not less than ninety (90) days after the stated RFQ closing date. Refer to Price Schedule for extended period.

11. Canadian Funds and Firm Prices

The prices quoted are to be in Canadian Funds and firm until delivery, acceptance and payment by the City for the work and services stated in this RFQ.

12. Time is of the Essence

The City shall have the right to cancel at any time any contract or any part of any contract resulting from this RFQ in respect to the goods, materials, articles, equipment, work or services, covered thereby, not delivered or performed by the specified time in the RFQ, without incurring any liability whatsoever in respect hereto.

13. Omission & Mis-statements

- a) The several parts of the RFQ shall be taken together to explain each other, and to make the whole consistent; and if it be found that anything has been omitted or misstated, which is necessary for the proper performance and completion of any or the requirements of the RFQ contemplated, the Supplier shall, at the Supplier's own expense, and without making any extra claim, therefore, execute the same as if it has been properly described, and the correction of any such omission or mis-statement shall not be deemed to be an addition to, or deviation from the requirements hereby contracted for; nor shall such decision or correction entitle the Supplier to any extension of time for the delivery of the items stated herein.
- b) It is to be understood that all terms and conditions, specifications, drawings, plans, all RFQ clauses, and the complete RFQ as originally issued by the Supply and Services Section of The Corporation of the City of Niagara Falls shall constitute the RFQ. Any Quotations received that have clauses or any wording or figures, statistics, numbers, quantities or any other items that have been changed or altered in any way shall be rejected and not accepted by The Corporation of the City of Niagara Falls.

14. Contract

Prior to an award, this RFQ and the Quotation submitted by the Bidder becomes part of the Contract. The Bidder must accept the City's Purchase Order which will supersede all other contracts. The City reserves the right to reject any Quotations submitted which may be restricted by the clauses or by any agreements or by restrictive statements of any kind in a Bidder's Quotation submission.

15. Agreement in Writing Only

No verbal arrangement or agreement, relating to the goods, materials, articles, equipment, work or services, specified or called for under this RFQ, will be considered binding, and every notice, advice or other communication pertaining thereto, must be in writing and signed by a duly authorized person.

16. Standards and Legislation: Failure to Comply

The Supplier may be required to provide written documentation that all materials proposed meet Municipal, Provincial and Federal Government standards, legislation and laws. Also, the Supplier must comply with all laws, legislation, regulations, and provisions of the Federal, Provincial, Municipal Governments or any governmental agency as they pertain to the specifications described herein. Failure by the Supplier to comply with these laws, legislation, regulations and provisions shall be just cause for the City, at its sole and unfettered discretion, to cancel the award and issue an award to any other Supplier or may re-issue the RFQ. The City may assess against the Supplier any damages whatsoever as a result of failure to comply.

17. Failure to Comply with all RFQ Terms

Failure to comply with all terms, specifications, requirements and conditions of this RFQ including delivery, to the satisfaction of the City, shall be just cause for the cancellation of the contract award. The City shall then have the right to award this contract to any other Supplier or Suppliers or to re-issue the RFQ. The City shall assess against the Supplier any damages whatsoever as a result of failure to comply with the said terms, specifications, requirements, conditions and delivery.

18. Goods and Materials Suitable for Use

The Bidder warrants that any goods, materials, articles or equipment to be supplied under or pursuant to any official order or contract based on this RFQ, that is or are to be made or used for a particular purpose, will be fit and suitable for that purpose.

19. Completion of Contract Terms and Conditions

- a) The goods, materials, articles, equipment, work or services, specified or called for in or under this RFQ shall be delivered or completely performed, as the case may be, by the Supplier as soon as possible and in any event within the period set out herein as the guaranteed period of delivery or completion.
- b) The Bidder agrees to furnish to the City, in conformity with the conditions set out herein and with any specifications, plans, price schedules, samples, instructions, addenda or other details, provided in connection therewith or referred to therein, the goods, materials, articles, equipment, work or services so specified or called for in this RFQ at the prices quoted herein and upon receipt of an official order therefor.

20. New Goods and Materials Only

Unless otherwise stated all goods supplied as a result of this RFQ shall be new only, never used, of the latest manufacture and not re-manufactured.

21. Patents, Intellectual Property Rights, Copyright, Trademarks, Technology Rights

By submitting a Quotation, the Bidder warrants that the information contained in its Quotation submission does not infringe any Patents, Intellectual Property Rights, Copyright, Trademarks, Technology Rights of any Third Party and agrees to defend the City at the Bidder's own expense, including all legal and court fees, in all suits, actions or proceedings in which the City is made a defendant for actual or alleged infringement of any Canadian or foreign letters patent, intellectual property rights, copyright trademarks, technology rights or any other related rights to the above resulting from the City's contractual relationship with the Supplier and the Supplier's use of any or all technologies, methodologies, strategies in providing the services required herein. The Bidder further agrees to pay and discharge any and all judgments or decrees which may be rendered in any such suit, action or proceeding against the City. The Bidder agrees to indemnify and hold harmless the City from any and all license, royalty and proprietary fees or costs, including legal and court costs, which may arise out of the City's contractual relationship with the Bidder and the Bidder's use of any or all technologies, methodologies, strategies in providing the services required herein. It is expressly agreed by Bidder that these covenants are irrevocable and perpetual.

22. Payment

- a) The normal payment terms offered by The Corporation of the City of Niagara Falls is net 30 days. Payment terms shall only be modified at the sole discretion of the City to take advantage of discounts for prompt payment or for other terms that shall be deemed to be in the best interests of the City.
- b) The Bidder agrees that the City shall be entitled to the discount stated herein if payment of invoices for the goods, materials, articles or equipment, work or services, specified or called for in or under this RFQ, is made within the period specified herein after acceptance or satisfactory completion thereof, as the case may be, and the receipt by the City of the invoice therefor.

23. Quotation Preparation Costs

The City shall not be responsible for the costs incurred by any Bidder to prepare and submit a Quotation or any subsequent documents relating to their Quotation submission.

24. Origin of Goods and Materials

Wherever possible, the goods, materials, articles or equipment, specified or called for in or under this RFQ shall be of Canadian origin and manufacture.

25. Erasures and Alterations

Any erasures, alterations or cross-outs must be initialed in ink by the Bidder. Failure to do so may result in the rejection of the Bidder's Quotation submission by the City.

26. Extension of Purchase Order

The time period duration of any Purchase Order issued as a result of this RFQ may be extended for a specific period provided that both the City and the Supplier agree to such extension. The City may notify the Supplier at any time to seek an extension.

27. Additional Requirements

The Corporation of the City of Niagara Falls reserves the right to add or delete items listed herein following award of any contract(s) or purchase order(s) resulting from this RFQ. The unit prices stated by the Bidder shall apply.

28. Delivery Information

- a) The prices stated in this RFQ cover the goods, materials, work, services, articles or equipment, referred to herein, being delivered F.O.B. destination, freight, express, duty and all other charges prepaid, unless otherwise indicated herein. A detailed delivery ticket or piece tally, showing the exact quantity of goods, materials, articles or equipment, shall accompany each delivery thereof. A storekeeper's or other receiver's receipt shall not bind the City to accept the goods, materials, articles or equipment covered thereby, or the particulars of the delivery ticket or piece tally therefor.
- b) In the event that goods, materials, articles or equipment, specified or called for herein, are to be furnished from a point outside Canada at a price which is expressly not to include importation charges into Canada or delivery in the Niagara Falls area, the Canada Customs Invoice in quadruplicate, with Bill of Lading, Export Entry form, Express receipt of advice of shipment by Parcel Post, shall be delivered to the Finance Department, P.O. Box 1023, Niagara Falls, Ontario, Canada, L2E 6X5.
- c) Should an additional tax or duty or any variation in any tax or duty, become directly applicable to goods, materials, articles or equipment, specified or called for in this RFQ, subsequent to its submission by the Bidder and before the delivery of the goods, materials, articles or equipment, or the completion of the work or services covered thereby, pursuant to an official order issued by the City the appropriate increase or decrease in the price of such goods, material, articles or equipment, shall be made to compensate for such changes as of the effective date thereof.
- d) Unless otherwise stated, all goods, materials, articles or equipment supplied, and all work or services, performed, pursuant to this condition shall be subject to inspection by the City at the point of unloading or the site of the work or services. No extra charge shall be made by the Supplier for packaging, packing or containers, unless otherwise indicated herein.
- e) The Bidder agrees that the goods, materials, articles, equipment, work or services, specified or called for in or under this RFQ, will be delivered or completed within the period set out herein as the guaranteed period of delivery or completion after receipt of an official order therefor.

29. W.H.M.I.S. Requirements

The Supplier must supply a supplier label and appropriate Material Safety Data Sheet under the W.H.M.I.S. legislation and Hazardous Protection Act for all controlled products to be supplied per this RFQ. Any controlled good supplied without appropriate data sheet and proper labeling will not be accepted and will be returned at the sole cost to the Supplier.

30. Indemnification

- a) The Supplier shall indemnify and save harmless the City from and against all claims, actions, losses, expenses, costs, demands, suits and other proceedings or damages of every nature and kind whatsoever which the City, its employees, officers or agents may suffer as a result of the negligence of the Supplier, its employees, officers or agents in performance of the Contract.
- b) The Supplier shall indemnify and save harmless the City from and against all claims, actions, losses, expenses, costs or damages of every nature and kind whatsoever which the City, its employees, officers or agents may suffer as a result of misuse, misappropriation or alleged misuse or misappropriation by the Supplier, its employees, officers or agents of intellectual property in the performance of the Contract; and
- c) The City agrees to indemnify and save harmless the Supplier from and against any and all claims, losses, damages, liability and costs arising out of or in any way connected with the presence, discharge, release or escape of contaminants of any kind, excluding only such liability as may arise out of the negligence of the Supplier in the performance of supplying goods to the City.

31. Notification of Potential Bidders Not Guaranteed

The City posts notification of all RFQ's on its Bid Opportunities Web Page. Bidders are to review the City's Web Site to inform themselves of any RFQ's. The City shall not guarantee that any previous Bidders shall be notified by any means electronic or otherwise of any RFQ. It is the responsibility of any potential Bidder to make inquiries with the Supply and Services Section of the City regarding any current or upcoming RFQ.

32. Removal from Bidders List

The City reserves the right to remove from its list of Bidders, for an indeterminate period, the name of any Bidder who fails to accept a Purchase Order issued by the City or for unsatisfactory performance on any previous or current contract held with the City or if the Bidder is currently involved in or responsible for litigation of any kind against the City.

33. Bidder's Expenses

Bidders are solely responsible for their own expenses in preparing a Quotation and for subsequent negotiations with the City, if any. If the City elects to reject all Quotations received, the City will not be liable to any Bidder for any claims, whether for costs or damages incurred by any Bidder in preparing their Quotation, loss of anticipated profit in connection with any final contract, or any other matter whatsoever.

34. Limitation and Waiver of Damages

The Bidder, by submitting a Quotation, agrees that it will not claim damages, for whatever reason, relating to the contract or in respect of the competitive process. The Bidder, by submitting a Quotation, also waives any claim for loss of profits if no agreement is made between the Bidder and the City.

35. Order of Precedence

In the event of any inconsistency or conflict in the contents of the following which shall take precedence and govern in the following descending order:

- Purchase Order
- Addenda (if any) as issued
- RFQ as issued by the City
- Quotation submission received from the Bidder

36. Rights to Quotation Submission

Upon receipt of the Bidder's Quotation submission, the City shall retain the right to determine the use of the said submission for its own purposes. Bidder's shall not use their Quotation submission for any other purposes whatsoever, including revealing any content of their Quotation submission or making copies for other agencies, firms or companies not being a legal part or division of the Bidder's company, unless permission for any such use is receiving in writing by the Bidder from the Corporation of the City of Niagara Falls. Bidders must make a request in writing to the City for the intended use of their Quotation submission for any other purposes than as stated herein.

37. Anti Lobbying Restrictions and Required Disclosure

- a) Bidders, their company staff members, or anyone involved in preparing their Quotation submission must not engage in any form of political or other lobbying whatsoever with respect to this project or seek to influence the outcome of the RFQ and subsequent procurement process. This anti-lobbying restriction extends to all City staff and elected Council members of the City.
- b) In the event of any such lobbying, the City may reject any Quotation submission by that Bidder without further consideration and terminate that Bidder's right to continue in the RFQ and any subsequent procurement process. All correspondence or contact by interested parties with the City must be directly and only with the City contact person identified in this RFQ. It should be duly noted by all Bidders that this anti-lobbying restriction extends from the release date of this RFQ through to the date and time when the City formally awards the contract by purchase order or other means. Any lobbying undertaken during this time frame by any Bidder or the Bidder's company staff members, or anyone involved with their Quotation submission may result in immediate disqualification from the process. This anti-lobbying restriction is not meant to affect the day-to-day operations of the City, its staff and the elected Council of the City that may necessarily include contact with potential Bidders to this RFQ regarding other business.
- c) This section shall not be intended to disallow any meetings, interviews or clarifications requested or authorized by the City, its authorized staff, the City's representative for the requirements of this RFQ or their authorized designates.

38. Quotation Submission and Correspondence in English

Quotation submissions must be prepared in English and Bidders must be able to converse and correspond fluently in English directly or through an interpreter supplied by and at the total cost to the Bidder.

39. Liability for Errors

While the City has used considerable efforts to ensure an accurate representation of information in this RFQ, the information contained in this RFQ is supplied solely as a guideline for Bidders. The information is not guaranteed or warranted to be accurate by the City, nor is it necessarily comprehensive or exhaustive. Nothing in this RFQ is intended to relieve Bidders from forming their own opinions and conclusions with respect to the matters addressed in this RFQ.

40. Agreement with Terms

By submitting a Quotation the Bidder thereby acknowledges and agrees to all the terms and conditions of this RFQ. Bidders who have obtained this RFQ and any addenda electronically must not alter any portion of this RFQ or addenda. To do so will result in the rejection of the Bidder's delivered Quotation submission.

41. Modification of Terms and Addendums

The City reserves the right to modify the terms of the RFQ. Any modifications or changes to the RFQ will be issued in the form of an addendum or addenda. The RFQ and any addenda will be posted on the City's Bid Opportunities Web Site. It is the sole responsibility of any potential Bidder to check this Web Page often to inform themselves of any posted addenda. www.niagarafalls.ca/bids

42. Litigation with The City

No Quotation submission will be accepted from any Bidder or any related company who has a claim or has instituted a legal proceeding against the City or against whom the City has a claim or has instituted a legal proceeding, without the prior approval of City Council. This applies whether the legal proceeding is related or unrelated to the subject matter of this RFQ.

43. Suspension of Activity

- a) All Bidders are advised and put on notice that notwithstanding anything else contained in this RFQ that all Bidders are forewarned and advised that if the City chooses not to proceed with this RFQ process or any subsequent procurement process or any stage including, without limitation, the completion of the RFQ process, the commencement, implementation or completion of any RFQ process or other procurement process and/or the award, negotiation or the finalization of any agreement or contract and that accordingly, all Bidders acknowledge and agree that if any such processes are suspended, terminated or cancelled at any time or times during any stage of the RFQ or subsequent procurement process (if any) by the City, then the Bidders shall have no claim against the City for any costs, expenses, losses including loss of profits, liabilities or damages whatsoever.
- b) The City reserves the right to exercise complete and unfettered discretion in all aspects of the conduct of the RFQ and any subsequent procurement process, the assessment and evaluation of Quotation submissions, including the determination of criteria and the choice, if any, of a Supplier or Suppliers without incurring any liability whatsoever to any Bidder, including any liability for costs, expenses, losses or damages, and without giving any reasons therefore.
- c) Without limiting the generality of the foregoing, the City, in its sole and unfettered discretion, reserves the right to change the dates, schedules and deadlines set out in this RFQ, or to change the scope of the project, or to cancel the RFQ or the Project, without stating reasons therefore and accordingly the City also reserves the right to accept or to reject any or all of the Quotation submissions and the City reserves the right to proceed as, in its sole and unfettered discretion, following receipt of the Quotation submissions, including, without limitation, issuing a second or more, or a modified RFQ for the project or entering into contract negotiations with any Bidder.
- d) The lowest priced Quotation submission received will not necessarily be accepted.
- e) The issuance of this RFQ and the receipt of any Quotation submission by any Bidder does not commit the City to award a Purchase Order or to pay any costs incurred in the preparation of any Quotation by any Bidder, or in any Bidder's attendance at any meetings with the City.

44. Adjustments to Quotation Submissions After Closing Date

No adjustments by any Bidders to their Quotation submissions will be permitted after the stated closing date for this RFQ, except as otherwise provided herein.

45. Decision by City

The Bidder agrees that by submitting a Quotation in response to this RFQ that the City has no obligation to reveal any information regarding any Quotation submitted to the City including the results of the RFQ process or any reasons for its decision in the choice of a Supplier or Suppliers.

46. Choice of Suppliers

The City reserves the right to issue Purchase Orders to one or more Suppliers, for all or individual items stated on the Price Schedule pages. The selection of the items to be ordered (if any) by the City shall remain the sole determination by the City.

Request for Quotation RFQ17-2012

**SECTION 2 - PRICE SCHEDULE
MOBILE LIFTS - NIAGARA FALLS TRANSIT**

I/We the undersigned hereby submit price, (taxes extra), which includes supply of mobile lifts, delivery F.O.B. to Niagara Falls Transit, 4320 Bridge Street, Niagara Falls, Ontario, which is to be in accordance with this Request for Quotation.

All Price Schedule pages be completed and signed by the Bidder. Quotations submitted without these pages completed and signed and without the Specifications and warranty information and all other required information attached to this Price Schedule Form **will be rejected. Prices below for NEW Mobile Lifts only.**

Description	Bidder to complete:
Supplier or Company Name	
Address: Street # and name	
Municipality - Province- Postal Code	
Telephone Number	
Fax Number	
E-mail of person signing below	
Authorized Signature I have the authority to bind the company	
Name of above signed person <i>please print or type</i>	
Date Signed	

Bidder's must attach warranty information and all other required information to the Price Schedule Pages

Request for Quotation RFQ17-2012

SECTION 2 - PRICE SCHEDULE**MOBILE LIFTS - NIAGARA FALLS TRANSIT**

Name of Company (Supplier)	
Authorized Signature per Page PS 1	

Price Complete including supply, delivery, warranty and all other costs, taxes extra. The Price as stated below to be firm for the period March 9, 2012 to December 31, 2012. The quantity stated below is an estimate only and must not be understood as a firm order quantity

Description	Quantity	Unit Price	Extended Price
Supply and delivery of Six (6) Mobile Lifts per all requirements of this RFQ, and including warranty as stated by the Bidder and attached to this Quotation.	6	\$	\$

Amount of Good and Services Tax	\$
Total Bid Price including Taxes and all other Costs	\$
State delivery time in calendar days following receipt of Purchase Order from the City of Niagara Falls	/ days
Bidders must State Yes or No to Both of the Following Statements:	
The Mobile Lifts offered are per the Specifications of this RFQ: State: Yes or No	
The Mobile Lifts offered are not per the Specifications of this RFQ and a complete set of detailed specifications are attached. State: Yes or No	

Bidders must attach to this page, **complete warranty details** for the mobile lifts stated above.

Bidder's who are submitting mobile lifts that are in any way different to the specifications as listed in this RFQ must attach a **complete set of detailed specifications** to these Price Schedule Pages. These specifications must also include names of a minimum of three (3) companies and the companies' phone numbers where the mobile lifts offered have been installed during the past three years. Alternative Bids submitted without the said specifications attached **will** be rejected.

Companies stated by the bidder as references will be contacted by City of Niagara Falls Staff. Both written and telephone (oral) references checks received by the City will be accepted as binding upon the bidder. References received which are negative or indicate past performance issues may be cause for the City to reject the bidder's quotation submission. Bidders also upon request by the City may be required to furnish satisfactory evidence as to their experience, capacity and financial resources.

By submitting a Quotation in response to this RFQ, the Bidder acknowledges and agrees that The City of Niagara Falls may issue purchase orders to one or more Suppliers or place orders for more or less quantities of the above items or for all or less of the above items or to cancel this RFQ in its entirety for reasons that provide the best value for and are in the best interest of the City for which the Bidders agree and acknowledge that they shall have no claim against the City.

City of Niagara Falls
Mobile Lifts - Niagara Falls Transit
SPECIFICATIONS

SECTION 3

Model PKMC18-4 & PKMC18-6 Heavy Duty
4&6 Column Configuration
Electro-Hydraulic Lift

A. Scope

1. This specification is for an electric hydraulic portable heavy-duty wheel-cradle type mobile column lift to permit lifting of highway vehicles (buses, trucks, etc.), weighing up to 72,000 lbs for four post and 108,000 lbs six post set for inspection, cleaning and maintenance. This equipment shall not require any in-ground, pits, or special foundations. This is the only type of lift that shall be accepted. Fixed above ground track lifts, parallelogram, scissor type, or in-ground lifts are not acceptable.
2. All equipment shall be new and unused. The model being bid must be the manufacturer's current production model. Used, reconditioned, leftover or discontinued models shall not be accepted.
3. Equipment must comply with all applicable federal, state, and local regulations and meet OSHA, UL-201, NEC, and be built to the latest ANSI/ALI ALCTV 2006 standards and it is third party certified .
4. Safety decals must be permanently placed on the lift in clear view of the operator.
5. The vendor shall submit drawings of overall dimensions, utility requirements, parts lists, maintenance requirements, operator manuals and descriptive product literature with its bid.
6. The manufacturer must be a firm regularly engaged in the design and manufacturing of the type of equipment specified herein for a minimum of 3 years. Manufacturer shall make parts available for the useful service life of the lift or no less than 10 years.
7. The intended purpose of this lift is for under vehicle service of all customers' vehicles. All components shall be water resistant and construction of lift shall be of such design as to be impermeable to water, snow and ice.
8. All material thickness and structural dimensions are minimum dimensional tolerances unless noted are as follows; $\pm 1/8$ " inches for dimensions less than 10 inches; $\pm .1/4$ " inches for dimensions from 10 inches to 5 feet inclusive; ± 1.0 inches for dimensions greater than 5 feet.
9. This lift system shall consist of four (4) electro-hydraulic mobile columns with cradle lift carriages, controls, and power distribution electrical connectors. The system will operate as a set of four columns. The system will also operate in "pair" mode or as a "single" unit. Lift shall be provided with an electric/ hydraulic power unit providing pressurized oil to a hydraulic cylinder mechanically attached to the carriage, which supports the adjustable width tire engagement forks.
10. The lift operation shall be controlled by a programmable logic control to ensure synchronized movement within $1\frac{1}{2}$ " of the carriages in either "raise" or "lower" mode through their full range. The synchronized movement shall be in either "all" or "pairs" mode as selected at the master control panel. It shall not be necessary for the operator to do any separate switching. Failure of any single column shall stop the entire unit from traveling.
11. Pressure relief valve shall prevent overloading of the power unit. Micro switches are not acceptable. Unit shall self synchronize on the downward stroke by means of a PLC controlling two lowering valves lowering valve. The unit shall automatically stop after reaching the end of its downward stroke.

City of Niagara Falls
Mobile Lifts - Niagara Falls Transit
SPECIFICATIONS- SECTION 3

A. Scope....continued

12. Units shall operate in pairs if desired. When switching back to “all” mode, units shall commit to memory the paired preset position and maintain level as such.
13. Units shall provide for individual control of each column. Individual carriages can be raised or lowered by pressing the “single” mode button and the “up” or “down” button simultaneously. No separate switching shall be necessary to return to pairs or all operation.

B. Equipment

14. Complete assembly shall consist of four (4) electro-hydraulic lift units, control boxes, and any accessories as specified herein. Each unit shall have its own hydraulic power pack, and piston. Acme screw thread or helical ball screw designs requiring upper and lower travel limit switches shall not be acceptable.
15. Each column shall have a minimum capacity of 18,000 lbs. The total lifting minimum capacity shall be a combined total 72,000 lbs for four post and 108,000 lbs for six post set.
16. Lifting stroke shall be 67” minimum. This dimension is measured from the floor to the bottom of the cradle and 71” to the top of the fork when the lift is at full height.
17. Column height shall be no more than 96 ½”. When fully raised the column shall be no more than 141 ½”.
18. Lifting unit shall permit lifting of vehicles to any height up to the full amount specified herein with no less than 19 locking positions throughout the lifts travel.
19. Safety systems- the lifting system shall incorporate multiple redundant safety systems. The unit shall maintain level vehicle position in the event of a mechanical failure, motor failure, hydraulic failure or loss of electrical service by using multiple electrical, mechanical, and hydraulic safety systems.
20. The lift shall incorporate a multiple position safety lock ladder on all posts, through the full length of travel. A spring loaded, positive rake, jam lock safety bar, shall be applied at all times except during lowering. Electric brakes are not acceptable. Locks shall have no less than 19 positions spaced every 3” beginning at 8” of travel thru the full stroke. Safety device shall be a 2” steel wedge, minimum.
21. The mechanical locks shall be released by a single point lock release when the down button that is located on the control panel and on every single column is pressed.
22. Mechanical locks are located in each post. The locks shall be mechanically engaged by gravity with a spring loaded back-up and released with (1) electric solenoid activating each lock. Each safety shall have a manual override lever to allow for manual lowering without electrical power.
23. Lift shall incorporate electrical safeties to monitor the position of all carriages simultaneously. Electrical safety system shall engage whenever any single carriage differs in height from any other carriage by more than 1 ½”. Electrical safeties shall either cause the out of level condition to auto-correct or shall stop all units and notify operator of a fault condition.

City of Niagara Falls
Mobile Lifts - Niagara Falls Transit
SPECIFICATIONS - SECTION 3

24. System must incorporate an integral hydraulic safety system including electrically operated solenoid valves and velocity fuses to prevent uncontrolled descent in the event of a hydraulic failure.

C. Lifting column

25. Each column upright shall be constructed of (2) 5 ¾" x 2 ⅛" x 7/8" forklift mast channel for maximum compression strength and rigidity. Channels shall be rigidly supported and joined together at the base with ½" steel plate using 3 point fillet welds. A ¼" steel plate and ¼" x 4" bar shall enclose column structural. Formed columns with, "h-beams" or columns without fork lift mast channels in each corner are not acceptable.
26. Each column shall have a base plate made from ½" steel plate and 3" x 6" rectangular structural tubing forming the footprint, minimum. The overall footprint dimensions shall be 43" x 38 ½", minimum.
27. Column bases shall provide a stable platform for vehicle lifting capable of a full height, fully rated lift, at 3 degrees off plumb. Each column shall be equipped with a pallet style jacking/steering mechanism.

D. Steering/ Jacking

28. Each steering wheel shall be of a pallet jacking mechanism design with two 8" phenol plastic coated steel wheels and build in pressure relive valve to prevent overloading of steering wheels . Steering wheels shall be raised and lowered by means of an OSHA approved handle with "raise" "lower" and "neutral" positions. Spring loaded or collapsible style steering wheels are not acceptable.
29. Forward front wheels shall be steel 6" in diameter with steel needle bearings for ease of movement. Plastic wheels will not be accepted.
30. Columns shall be designed to be moved easily by one person. Jacking mechanism shall raise the column off the ground, to move across rough surfaces, pallet style jacking mechanism shall automatically retract if operator attempts to raise a vehicle before lowering jack.

E. Carriage assembly

31. Tubing supporting the wheel cradle joined to a 3/8" backing plate by 3 point fillet welds, minimum. All structural tubing shall have end caps welded in place to minimize pinch points and internal contamination/ rusting.
32. Lifting forks shall provide safe, stable support of vehicle wheels. Lifting forks shall be constructed of ½" x 3 ½" x 5" angle.
33. Carriage lifting forks shall be adjustable to accommodate a full range of tire sizes without the use of adapters. Adjustable forks shall fully enclose the lifting carriage to prevent slippage or any unintended movement and shall be securely fastened in position by use of a clevis pin.
34. Carriage forks must be adjustable from 13" – 23 ½". Adjustable lifting forks must handle up to a 48" tire size.
35. Each carriage fork must have a low profile approach angle to accommodate large floatation type tires without modification or drive-up floor pads to raise the tires. Fork angle shall not exceed 31° degrees.

City of Niagara Falls
Mobile Lifts - Niagara Falls Transit
SPECIFICATIONS - SECTION 3

36. The carriage shall accommodate optional equipment like : fork lift adapters, chassis beam adapters, and frame contact adapters for cars shall be accommodated with at any time in the future, without field modification.
37. The carriage assembly shall not require any monthly cleaning with solvents or any monthly lubrication. All wear surfaces shall be completely self-lubricating.
38. The carriage assembly shall roll up and down smoothly in the columns, on four (4) 4" steel bearings . These bearings shall be warranted against failure for the life of the unit. Bearings shall require minimal annual maintenance. Plastic or UHMW roller are not accepted.
39. Each of the (4) carriages shall be lifted by means of a direct drive lifting cylinder system. The carriage shall be connected directly to the top of the cylinder by (1) ½" diameter ASTM a-311 1½" class b hardened steel bolt to maintain non-wearing construction design. Mechanical screw type designs are not acceptable.
40. Carriage height at full rise shall be no more than 11' 8 ½".
41. Carriage top shall maintain 11" minimum distance from vehicle body when fully raised.

F. Power unit

42. Lifting speed shall be 60" per minute or 66 seconds maximum from the floor to full height.
43. The master control panel shall be attached to the main column with the operating controls. There will be one master control panel with a selector switch allowing for use in sets of four, pair or single operation. (plus three secondary on four post and 5 secondary on six post control panels supplied with each primary control panel.
44. The column with the master control panel must be capable of being placed in any position around the vehicle.
45. Control panel shall house the following equipment:
 - Momentary contact (dead-man) controls
 - Programmable logic controller
 - 2 column, column or column selector switch
 - NEMA 12 enclosure for electrical terminal strips
46. Fault sensor and indicator light, weatherproof wire connector with mechanical lock emergency stop button which shall stop all motion when pushed. Unit must be reset afterward to operate.
47. The control panels shall be built to NEMA 4 water resistant specifications with all lights and control switches included.
48. The connecting cables to each column shall have detachable plug connectors on each end.
49. Each electrical receptacle shall be numbered to identify its appropriate column connection.

City of Niagara Falls
Mobile Lifts - Niagara Falls Transit
SPECIFICATIONS - SECTION 3

50. Main power switch, water resistant and lockable, NEMA 12 rated.
51. All controls, warnings, and instructional information shall be oil resistant, laminated, or engraved in plastic. Metal serial tag shall be mounted on the main panel.
52. Supply voltage shall be applied in inter-connecting cables only when rising. At all other times, only 24-volt control voltage shall be allowed in inter-connecting cables. When lift is idle, no line voltages shall reside in interconnecting cables to eliminate the risk of an electrical hazard.
53. In the event of a power failure it shall be possible to lower each column without the use of any special tools. No disassembly of columns or hand cranking of drive mechanisms shall be necessary. Mechanical locks shall remain in position at all times unless manually released by the operator.
54. Plc controls shall prevent the startup of more than one motor at any time to prevent voltage spikes through control system. Electrical power input shall be allowed to one column only to eliminate any possible misinterpretation of power supply and/ or control cabling. Each unit shall accommodate a magnetic induction sensor package.

G. Secondary columns

55. Secondary columns shall house the following equipment:
 - Momentary contact (dead-man) controls (up and down) single unit operation mode.
 - NEMA 4 enclosure for electrical terminal strips.
 - Fault sensor at each column.
56. Emergency stop buttons which shall stop all motion when pushed. Unit must be reset afterward to operate

H. Electric motor

57. Motor shall be available in 208/230/440/460/480 volt, 3 phase, 60Hz, TEFC of North American manufacture. 1 motor shall be provided for each column, 2 hp minimum. Motor shall not require rework for replacement. Standard motor shall be 208-230/460 2hp 3 phase.
58. Motor shall be protected against electrical overload. Full load amps: 40 amps @ 208v, 36 amps @ 230v, and 18 amps @ 460v. Motors shall be totally enclosed and fan cooled against overheating.
59. Control voltage for all circuitry and carriage position sensors shall be 24 volts. All electrical components less than 18" off the floor shall be class i explosion proof rated.
60. Motors shall be fully enclosed for protection from incidental damage. Motor bearings shall be sealed for life, pre-lubricated for a minimum of 3 years use.

I. Electrical power cables

61. Minimum of 40' long 8 gauge 3/4" pvc coated with 4 internal wires communication cables 16 gauge.16 wire 3/4" with 15 mil PVC coating. Cable lengths can be specified by customer and suspended from the ceiling to accommodate standard and articulated buses.

J. Concrete

- Concrete must be a minimum thickness of 4" and have a pressure rating of 3000 psi.

K. Hydraulics

62. The lift shall incorporate a precision position sensor control system, capable of synchronizing carriage elevations during both raising and lowering operations with the most adverse rated load placed on the lift, with fore and aft and single over-ride controls to manually level the lift. System shall incorporate an easily replaceable toothed sprocket and chain with a proximity sensor.
63. Oil reservoirs shall be metal 3-gallon capacity. Reservoir and motor assembly shall be located below the center line of the column to assure low center of gravity.
64. Each hydraulic cylinder shall have a velocity fuse integrally mounted to prevent collapse in the event of a fluid leak..
Cylinder specification (4 cylinders total)
- Barrel outside diameter: 3.375"
 - Barrel inside diameter: 3.0"
 - Rod (chrome plated) diameter: 1.75"
 - Cylinder stroke minimum 67"
 - Operating pressure 3150 psi
65. Hydraulic cylinder shall be completely enclosed and protected by the carriage throughout its entire travel. A steel enclosure shall protect the piston against damage and contamination by debris. Plastic cylinder boots or vinyl sheeting is not acceptable.
66. The lift shall be driven by hydraulic gear pumps capable of supplying the appropriate pressure and flow to operate the lift.
67. Cartridge type oil filter, with a 10-micron filtering surface shall be located on the return flow port in the pump's reservoir.
68. Hydraulic fluid shall be AW 32 hydraulic oil or approved equal.
69. All hydraulic hoses shall be of steel reinforced construction, with a burst rating of 15,750 psig (minimum) and have standard JIC fittings.

Note: Drawing: Mobile Lift Column is attached to this page.

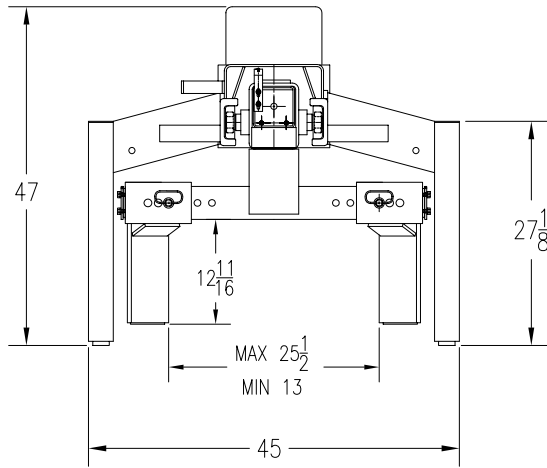

CAPACITY PER COLUMN - 18,000 lbs
 LIFTING HEIGHT UP TO 69"
 LIFTING SPEED - 69 seconds
 ELECTRIC/HYDRAULIC SYSTEM
 AUTOMATIC MULTI-POSITION MECHANICAL LOCK
 HYD. OPERATED THIRD WHEEL
 ADJUSTABLE FORKS (13" TO 25-1/2" INSIDE)
 STEEL ROLLERS, 7/8" THICK CHANNEL

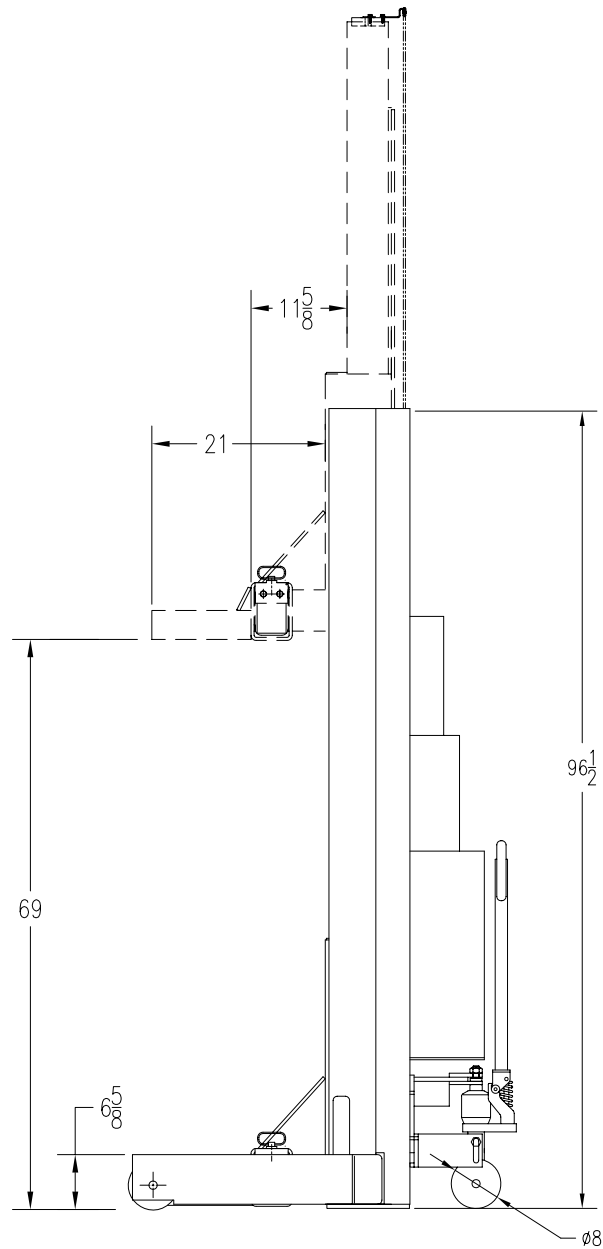
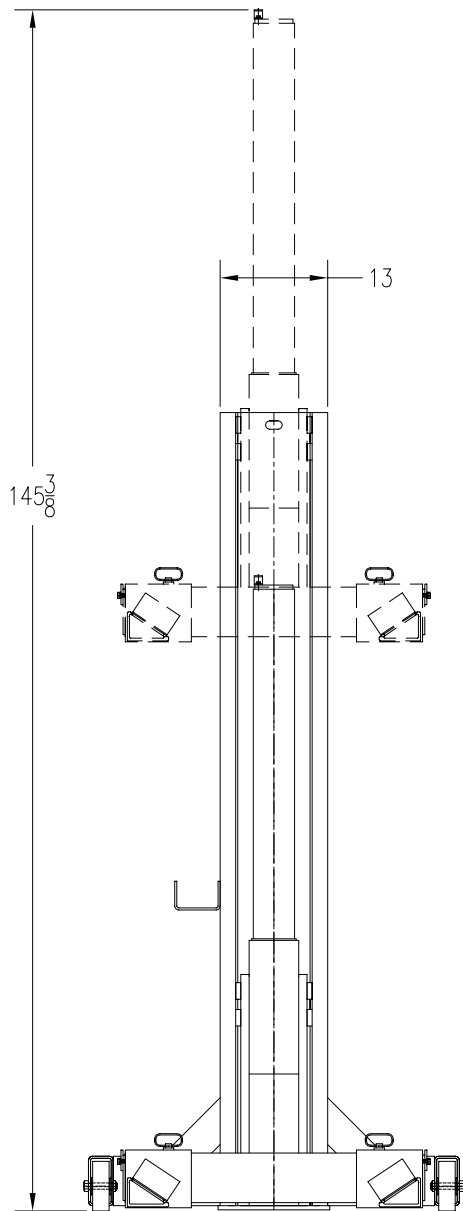

MOBILE LIFT COLUMN
 MODEL:PKMC18/69

FROM:

RFQ17-2012

Mobile Lifts - Niagara Falls Transit

CLOSING: March 8, 2012 - 2:00 p.m.

Quotation Submission

DELIVER UNOPENED TO:

The City of Niagara Falls
Municipal Service Centre
Front Reception
3200 Stanley Avenue
Niagara Falls, Ontario
L2E 6S4

ATTENTION: SUPPLY & SERVICES